



New Amplifier Technology Redefines Performance Benchmarks

NAD Masters Series M2 Direct Digital Amplifier

by: **Greg Stidsen**, Director, Product Development, NAD Electronics International
Craig Bell, Product Marketing Manager - Audio, Diodes Zetex Semiconductors Ltd.

New Amplifier Technology Redefines Performance Benchmarks

NAD Masters Series M2 Direct Digital Amplifier

By: Greg Stidsen, Director, Product Development, NAD Electronics International
Craig Bell, Product Marketing Manager - Audio, Diodes Zetex Semiconductors Ltd.

NAD Masters Series Concept

The NAD brand has come to represent high value products that consistently offer musically honest performance. In 2005, NAD introduced the Masters Series concept as the evolution of NAD's core values of performance, simplicity and value. Each component in the series offers performance, both measured and subjective, that is at the upper limits of today's technology. Elegant industrial design and impressive build quality are also essential to this concept. As a way to showcase its engineering prowess and to create a new class of NAD products, Masters Series has been a qualified success.

Another key element of the Masters philosophy is the introduction of new technology that can later trickle down to NAD's less expensive products. This is where our M2 Direct Digital Amplifier story begins.

The M2 Design Story

The first 'Class D' amplifiers for audio were developed in the 1960s by Gordon Edge, a brilliant engineer working for famed British entrepreneur Clive Sinclair (Sinclair Radionics). But the performance of this early design was marginal. In the 1970s, Infinity Systems experimented with a more advanced design called SWAMP, but could not advance this development into a commercially viable product. Thirty years later, Class D amplifiers are now widely used in both professional and consumer products, but not without compromise. Noted for higher efficiency when compared with linear Class A and Class AB amplifiers, Class D still has not been able to achieve the same levels of performance, both measured and subjective, as the best Class AB designs.

By the late 1990s the gap had narrowed considerably and NAD started experimenting with various Class D design solutions. But our investigations revealed that even when the amplifiers we measured performed well on paper, they did not sound very musical. Some were etched and dry sounding while others were soft and lacked high frequency extension and detail. All of them sounded less dynamic and less fluid than our reference Class AB amplifiers.

Because NAD considers performance to be its most important brand value, it was decided that an NAD branded Class D amplifier would not be introduced until it could offer equal or better sonic performance to NAD's traditional Class AB designs.

NAD and Diodes Zetex Collaboration

One of the most promising designs we tried came from a British semiconductor company named Zetex. The circuit architecture was fully digital, which differed greatly from most of the Class D amplifiers in the market. Conceptually, Zetex had addressed the major weaknesses of previous designs and early listening tests were extremely encouraging. The sound was open and dynamic without the harshness or softness of the other solutions. Transients were superbly rendered and the amp sounded fast and tight, but not overly etched or dry.

Zetex (now Diodes Zetex Ltd.) was looking for a development partner to bring their digital development out of the laboratory and into the marketplace. NAD's strong engineering resources and worldwide reputation for performance proved to be a good match and so NAD and Zetex started to collaborate in 2005. Our mission was to push this new digital platform to the limit and make a very powerful amplifier as the first introduction of this new invention. The design brief for the M2 started to take shape.

The Advantages of a True Digital Amplifier

Our initial thought was to make a basic power amp without any controls that could stand as a reference to other amplifiers. But one of the strongest attributes of a true digital amplifier is the ability to take a digital PCM signal directly, thus avoiding multiple conversions and amplifying stages that are present in all analogue designs, which tend to strip the music of detail by adding hazy layers of noise and distortion. Ever since the introduction of digital source material in the 1980s, a pure digital signal path was always an attractive proposition; now it could be a reality.



Analog Audio System

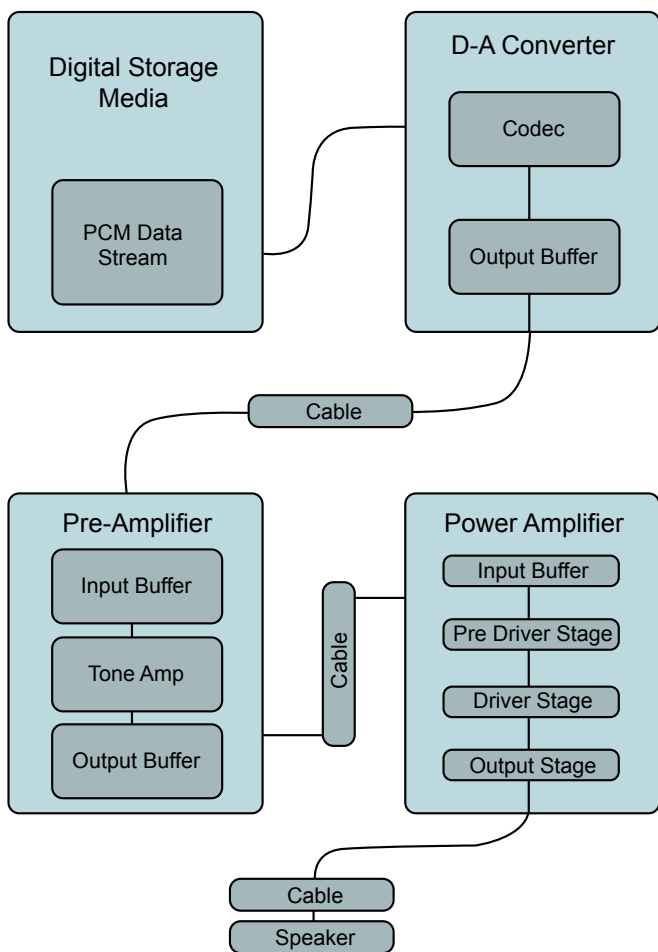

Direct Digital Audio System

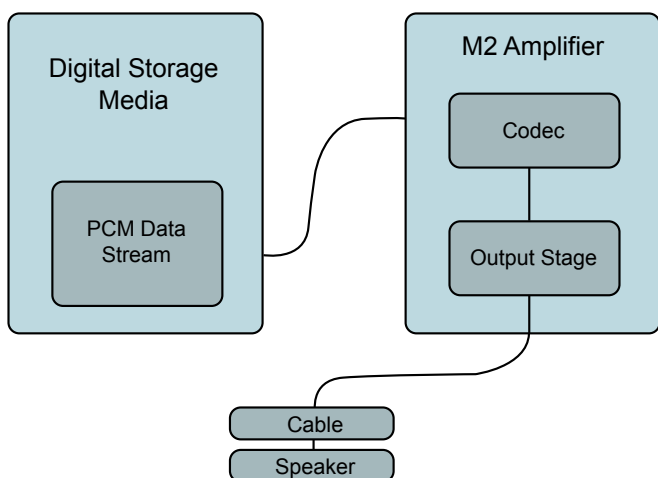

Although the early Zetex prototypes already had very good sound quality, the measured performance was still not quite up to the best available amplifiers. The first prototypes showed performance that was typical of the best available digital amps with a measured SNR of 105dB referenced to full power. But the NAD standard is >90dB referenced to 1 watt – we needed to find an additional 10 – 15dB of dynamic range. With 35-bit architecture it was theoretically possible to achieve this level of performance from the Zetex DDFA™ (Direct Digital Feedback Amplifier) circuit, and we were determined to achieve this goal. Step-by-step, as we made measurable improvements, the subjective sound also became more detailed and expansive. This was very encouraging and motivated the team to push further and further.

The benchmark SNR performance of >90dB Referenced to 1W is a difficult technical challenge, but it very closely relates to the noise performance at typical listening levels and discloses the absolute magnitude of the noise, which is the most honest way of declaring the performance. This performance level is delivered by NAD analogue power amplifiers, but we must consider how this power amplifier performance fits within the overall signal chain. We can now gain insight into the difference between a conventional analogue approach and a direct digital amplifier – and the opportunity it presents.

An extremely good digital signal source, such as a high-end CD player with a very well implemented DAC stage can offer an A-weighted SNR performance of perhaps 120dB-ref Full Scale, but the signal must be routed through a pre-amplifier stage before reaching the power amplifier stage, even if an integrated amplifier is involved. High-end pre-amps can have SNR performance ranging from 95dB up to 110dB ref FS, for the best examples. For a pre-amp, actual SNR performance is very dependent on the gain setting and can easily deteriorate by as much as 10dB from the optimal.

Analysing the overall noise generated in the signal chain quickly illustrates the dominance of the pre-amp to the overall performance, giving an end-to-end performance slightly worse than this link in the chain. The following example shows how the noise is developed within the system.



New Amplifier Technology Redefines Performance Benchmarks

NAD Masters Series M2 Direct Digital Amplifier - by: Greg Stidsen and Craig Bell

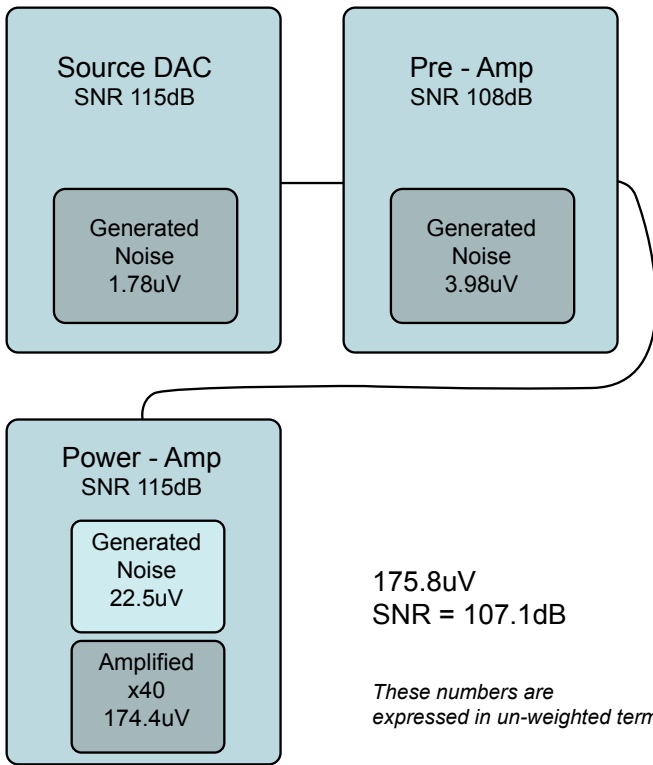

This 107.1dB figure is referenced to a 200W output power. Stating it referenced to 1W, gives a figure of 84.1dB. This is the true end-to-end performance of even this exceptional conventional signal chain. Even the outstanding power amplifier used in this example cannot help, if noise is presented at its input.

For the M2 digital amplifier, the situation is quite different. Starting at the source, a well executed digital output has no noise or distortion, beyond the fundamental limits of the number format. A Zero output is simply represented by zero in the PCM data. As it enters the digital amplifier, all pre-processing such as filters and volume controls are implemented in DSP, and as a consequence, are not subject to the effects of noise in analogue components, nor tolerances in their values. The DSP architecture selected for the M2 is very high resolution, with a minimum of 35 bits at any point in the processing datapath to ensure maximum retention of resolution.

Take the volume control as an example. The 35-bit system datapath means that even a 24-bit input signal has 11 bits of headroom, so the volume control can be set as low as -66dB without losing any of the original signal resolution. If the source was a CD player with 16-bit data, then the figure is astonishing at -114dB. While either of these levels is normally inaudible, the processing resolution involved is paramount to retaining and reproducing the subtleties of the original recording.

The only source of noise or distortion in the M2 architecture is the final

modulation and gain stage, where PCM data is converted to PWM (Pulse Width Modulation) to create the switching output. The system SNR performance is completely unaffected by the volume control setting, so audible noise is never evident at the speaker. More importantly, such a low level of noise and distortion translates directly to subjective performance. SNR performance of the M2 is 91dB ref 1W (un-weighted), in all circumstances.

How it Works

The modulation stage is the part of the M2 where the most critical innovations were required in order to hit the performance targets. The modulation process where PCM is converted to PWM is an inherently digital one, with the widths of the modulation pulses being quantized by the internal clock frequency, which in the case of the M2 is 108MHz. This means that pulses can be defined to a resolution of 9.2ns within a modulation period which is 1.18us long, for a maximum of 128 possible pulse widths. At first glance, this would seem to be much too small a number to represent an audio signal. However, there are many modulation cycles available within the period of even the highest audio frequency cycle, so noise shaping techniques can be applied to accurately resolve the signal. Put simply, varying pulse widths can be applied, so that the cumulative effect is to reproduce precisely the correct amplitude at the output.

The actual amplification step is performed by the FET output stage, which amplifies the logic level pulses from the modulator output levels (3.3V) to high voltage pulses with amplitude of approximately +/-50V, and fed to the speaker terminals through an LC or reconstruction filter, which removes the high frequency energy and delivers the audio signal to the speaker. The output stage is where the very real challenges of switching power electronics arise.

In reality, the pulses at the bridge output differ hugely from the perfect

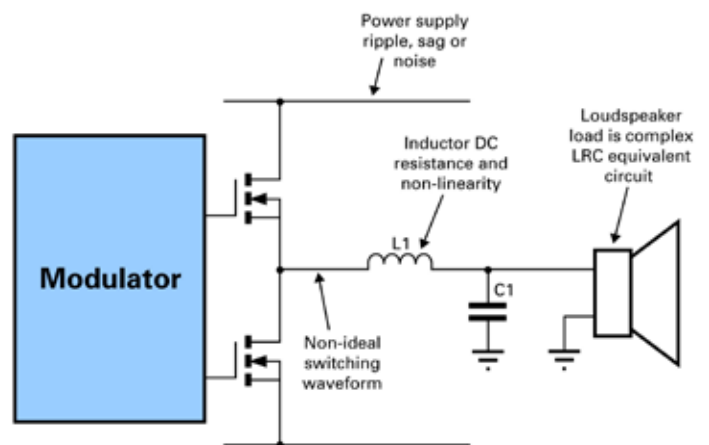

New Amplifier Technology Redefines Performance Benchmarks

NAD Masters Series M2 Direct Digital Amplifier - by: Greg Stidsen and Craig Bell

shape we might hope for, and the deviation from perfection results in errors in the output signal.

Most digital amplifiers are open loop and have no correction mechanism, so their performance falls far short of linear amplifiers. They cannot correct for the imperfections that are inevitable in power supplies, or real-life switching waveforms. Attempting to perfect the power supply or switching structures is not a practical approach, so the DDFA technology was developed to implement correction for the problems.

Feedback Re-invented

An analogue amplifier, whether linear or Class D, can use conventional negative feedback methods to compensate, but the problem is much more difficult for a true digital amplifier. The obvious method of digitizing the analogue output and feeding back to subtract from the input is hampered by the large delays involved and results in an unstable system.

To solve the problem, the Zetex team has developed an entirely new approach, which is best described as noise shaping error correction. Any deviation from the perfectly programmed pulse shape is regarded as an error. This could be caused by the amplitude of the pulse (power supply ripple or sag), the width of the pulse, or even the slope of the edges. Any of these factors will impact the area under the pulse (which is really how the signal amplitude is encoded).

The system operates by comparing the output PWM signal with a high purity

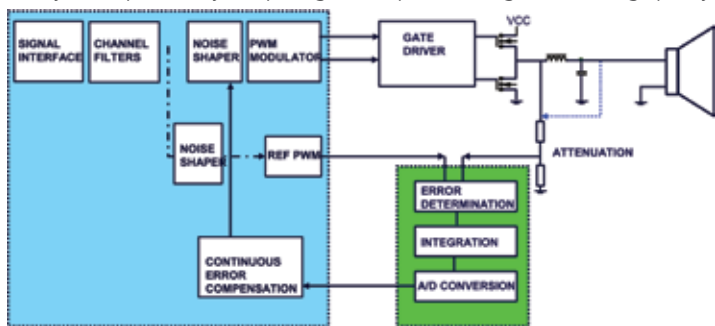

'Reference PWM' signal to create an error signal, which is representative of the voltage error at the output. Integration in time provides an indication of the pulse area error, which is digitized at a conversion rate of 108MHz to pass back to the digital domain. The error information is then processed to compensate subsequent modulation cycles. The system can be considered to be constantly adapting to minimize the errors and hence deliver as true a signal as possible to the speaker. The output signal is also monitored at the output of the LC filter, which means the system has

amazingly low output impedance. This very tight or direct feedback path gave rise to the name Direct Digital Feedback Amplifier.

The Engineering Challenge

The engineering challenge of making this process happen cannot be understated. For example, the reference PWM signal serves as the system's definition of perfection, so it must be highly pure. One familiar metric to illustrate the difficulty: clock jitter to achieve the necessary 120dB dynamic range of the reference signal must be at a level of 5 picoseconds! (A picosecond is one trillionth of a second or 0.000 000 000 001).

Another way to consider the M2 technology is to judge it as if it were simply a DAC. Think of the M2 as providing digital-to-analogue conversion with amplifier gain attached. During the development, a lot of attention has been paid to assessing the performance in these terms to ensure the most accurate possible reproduction. For example, the linearity of the M2 compares well to the claims of the highest performance DAC chips.

In fact the performance is so good the results at very low signal levels can

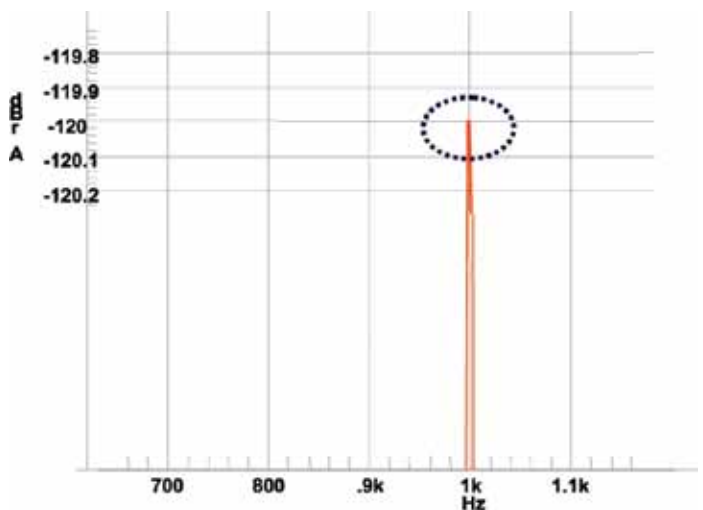
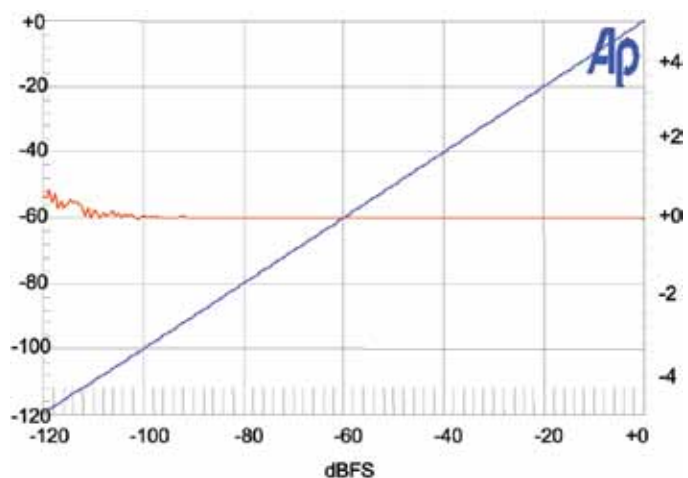

New Amplifier Technology Redefines Performance Benchmarks

NAD Masters Series M2 Direct Digital Amplifier - by: Greg Stidsen and Craig Bell

be misleading. At the lower end of the linearity plot, the measurement of linearity error is influenced by the noise present. By performing an FFT on the amplifier output using multiple averages, the outstanding amplitude accuracy becomes clear. The error level is less than 0.1dB at -120dB

Extremely low jitter is another impressive digital performance metric. Using the j-test to assess data-related jitter, the telltale side bands at 229Hz intervals from the fundamental are totally missing. Quite simply there is no jitter.

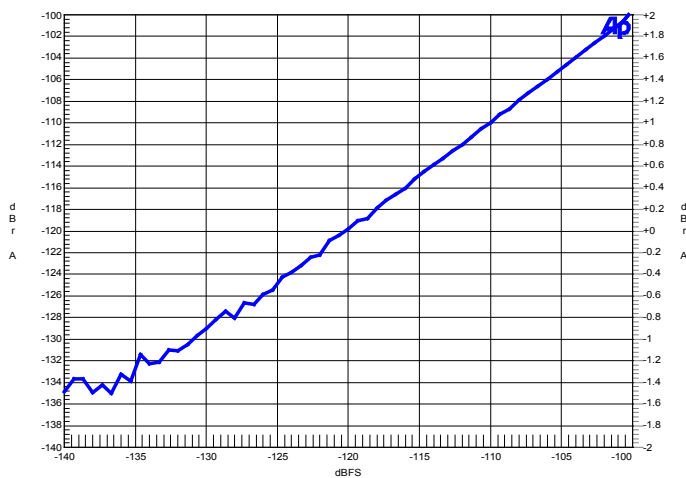
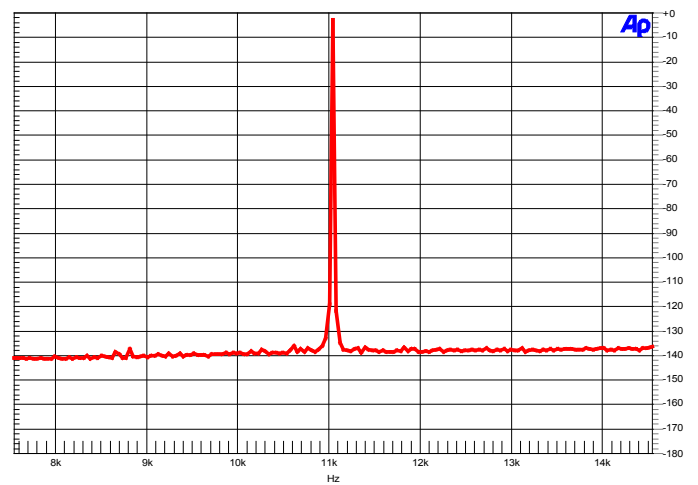
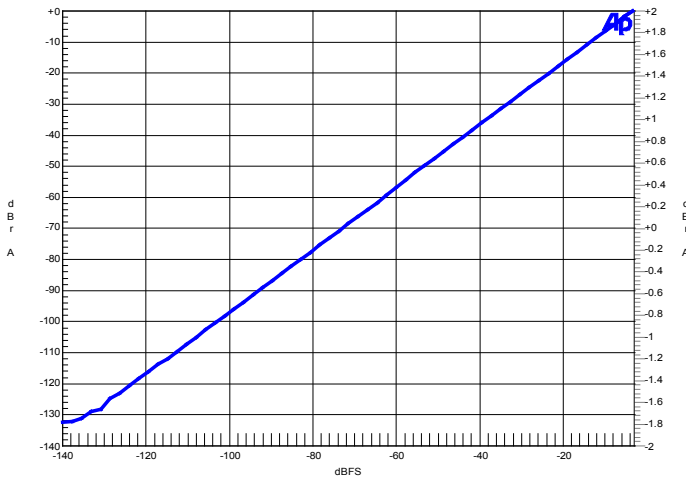

Measured Performance of the NAD M2 Direct Digital Amplifier

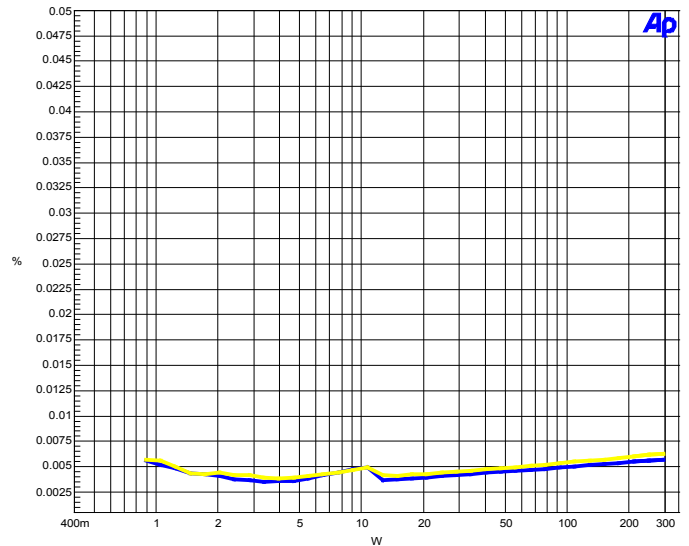

Zooming in further reveals useful resolution down to -135dB!

The familiar measurement of THD+N vs. output level shows the expected level of performance for a high-end amplifier. However, much more is revealed by looking at the M2 performance in terms of low level detail.



New Amplifier Technology Redefines Performance Benchmarks

NAD Masters Series M2 Direct Digital Amplifier - by: Greg Stidsen and Craig Bell

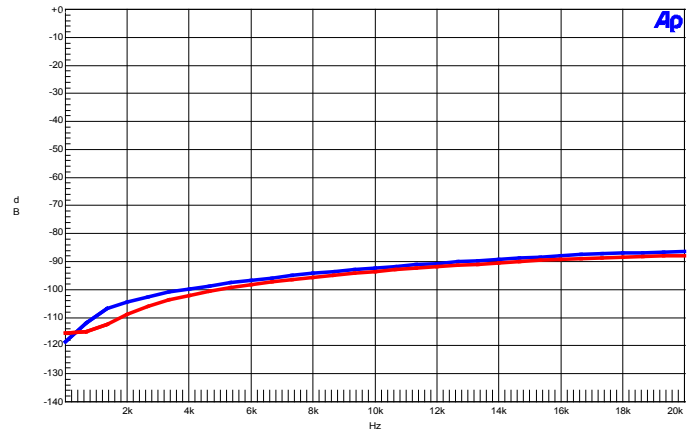
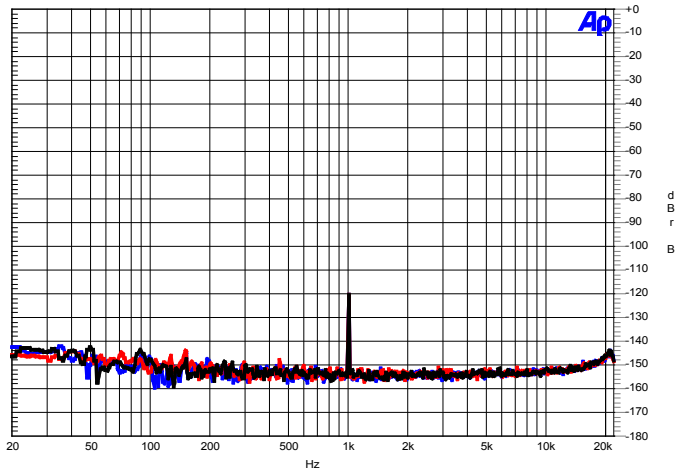

The conventional test for dynamic range requires a -60dB output. In testing the M2, we have gone several steps further in also testing with -120dB. It is remarkable that this small signal level is resolvable. It is also notable that the performance remains exactly the same over a broad range of volume settings. The chart shows identical performance over three gain settings separated by 40dB.

Channel Separation is greater than 90dB all the way up to 10kHz and still 85dB at 20kHz, which is 10dB better than the best analogue stereo integrated amplifiers.

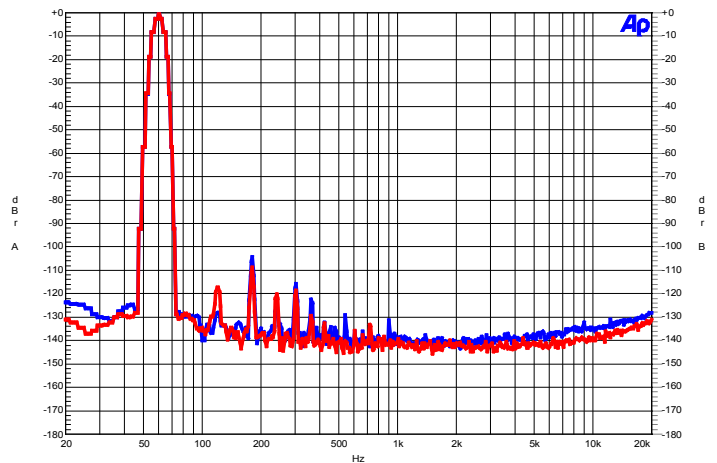
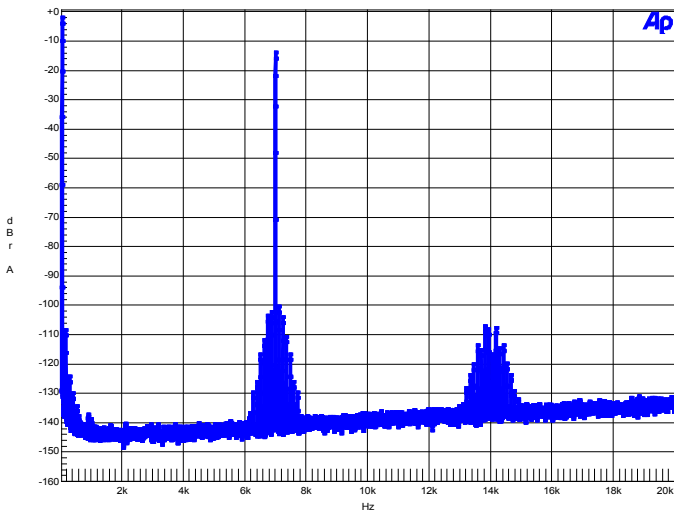

| Sweep | Trace | Color | Line Style | Thick | Data | Axis | Comment |
|-------|-------|-------|------------|-------|---------------|-------|---------|
| 1 | 1 | Blue | Solid | 1 | Fit.Ch.1 Ampl | Left | |
| 1 | 2 | Red | Solid | 1 | Fit.Ch.2 Ampl | Right | |

| Sweep | Trace | Color | Line Style | Thick | Data | Axis | Comment |
|-------|-------|-------|------------|-------|---------------|------|---------|
| 1 | 1 | Blue | Solid | 1 | Fit.Ch.1 Ampl | Left | |

Distortion spectrum of 60Hz signal at 250 watts into 8 ohms shows a very clean spectrum with higher order harmonics well suppressed.

SMPT E Intermodulation spectrum is very clean with all distortion products below -100dB or 0.001%.



New Amplifier Technology Redefines Performance Benchmarks

NAD Masters Series M2 Direct Digital Amplifier - by: Greg Stidsen and Craig Bell

NAD's Unique Implementation of DDFA

The M2 has taken Diodes Zetex's core technology and integrated NAD's many years of amplifier expertise to create a really unique product. The implementation of DDFA within the M2 uses customized logic within a Xilinx FPGA. This gives a custom platform on which to blend the DDFA technology with NAD's own innovations within this unique architecture.

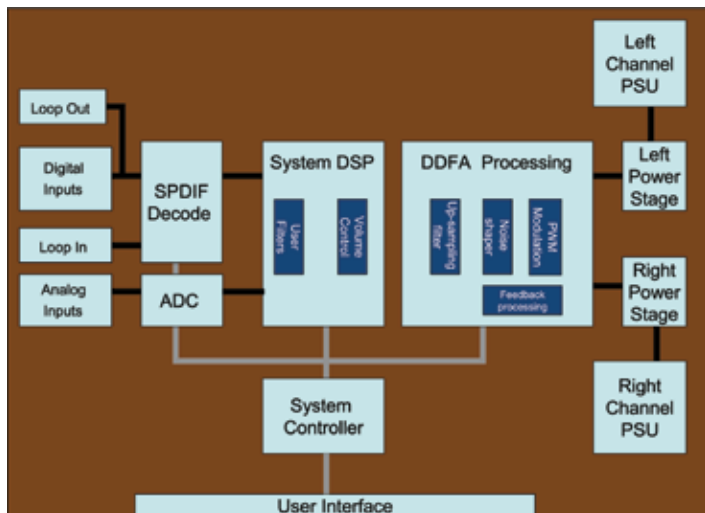

Digital PowerDrive™

The benefit of NAD's PowerDrive™ technology is the ability to have high dynamic power necessary for accurate reproduction of musical transients coupled with the ability to drive difficult speaker loads without increased distortion. The DDFA architecture allowed us to translate this important attribute into the digital domain giving a highly accurate power/time envelope that closely matches our 'ideal' based on NAD's research of recorded music requirements.

Digital Soft Clipping

NAD first developed Soft Clipping in the 1970s as a way to avoid the harsh and highly non-musical sound when an amplifier is driven beyond its limits. Soft Clipping allows a graceful overload without the usual generation of high order harmonic distortion that normally occurs as the sine wave gets squared off. Now digitally controlled, it can be carefully modeled for ideal results.

Perfect Digital Volume Control

Signal-to-noise, distortion and channel separation are the same for all control settings. Channel tracking is perfect. There is a fixed setting available for analogue inputs allowing the M2 to be used as a basic power amp with analogue preamps if desired.

Selectable Digital and Analogue Inputs

This allows the M2 to be used without a preamp for the shortest possible signal path. Both balanced and single-ended signal sources are supported.

Ultra-high Resolution Analogue-to-Digital Conversion

Analogue inputs must be converted to the digital domain of the M2. NAD is using the very latest state-of-the-art devices which, along with an optimized circuit design, results in superb performance. Sample Rate of 48kHz, 96kHz and 192kHz can be selected. The performance of the Analogue inputs is within 1dB of the Digital inputs for all measurements!

Speaker Compensation

Even though the DDFA corrects for the influence of the output filter, we offer further fine-tuning using digital filters to flatten response at 20kHz to within 0.5dB. Speaker impedances from 1 ohm to greater than 8 ohms are accommodated in 1 ohm steps.

Dual Mono Design

Three separate ultra low noise Switch Mode Power Supplies are employed – one for each audio channel and one for control.

Digital Processor Loop

This allows the insertion of a PC into the signal path to add signal processing such as crossover filters or room correction filters. Connection is via Optical SPDIF.

Two Sets of Speaker Outputs

This is to allow for convenient Bi-Wiring of loudspeakers.

Large VFD Display

The front panel display shows selected input, incoming Sample Rate, ADC Sample Rate, Volume Setting and Mute. Each input can be renamed if desired.

System Remote Control

IR remote controls NAD CD Players as well as the M2. Front IR Sensor and Rear IR Input.

12V Trigger Input

Allows for automated On/Standby function.

RS-232 Port

Interfaces to third-party automated control and allows for software updates.



New Amplifier Technology Redefines Performance Benchmarks

NAD Masters Series M2 Direct Digital Amplifier - by: Greg Stidsen and Craig Bell