



Owner's Manual

**Sage L150i
Biampified
Planar Magnetic Hybrid
Loudspeaker**

Table of Contents

Introduction	4
About this manual.....	4
Please register your system	4
Description	5
Planar magnetic panels	5
<i>Free from compression</i>	5
<i>More reliable</i>	5
<i>Easy on amplifiers</i>	6
<i>Line source behavior</i>	6
Dynamic woofers.....	7
<i>Big bass in small boxes?</i>	7
<i>Extraordinary drivers</i>	7
Designed for biamplification	8
<i>SC-1 System Controller</i>	8
Remote Setup via Modem.....	8
Unpacking & Installing the L150i	9
Room Acoustics & Placement	11
Start With the Room	11
<i>Rigid Walls</i>	11
Speaker Placement.....	12
<i>Left & Right Speakers</i>	12
<i>Center Channel</i>	12
<i>Surround Speakers</i>	13
Subwoofer Placement	13
Room Treatment	14
Professional Acoustic Design	14
References	15
Optimizing the System	16
Care & Maintenance	17
North American Warranty	18
Twenty Year Warranty.....	18
Obtaining Service	19
Specifications	20
L150i Bass Section Dimensions	21
L150i Planar Section Dimensions	22
Notes	23

Introduction

Congratulations on purchasing your Wisdom Audio system. It incorporates many design features designed to give you decades of pleasure and performance. Many of these design choices are uncommon among loudspeaker manufacturers, and bear some explanation. See the following section entitled “Description” for more information.

Our unique driver designs and our emphasis on achieving real-world performance account for the “system” approach taken. These are not speakers that are simply connected to speaker wires and promptly forgotten. We recognize that setting up a Wisdom Audio system is a bit more involved than connecting a common set of loudspeakers, which is why we insist that our dealers perform the installation and calibration of the systems. We know that the extra effort (particularly as regards setting up the SC-1 System Controller) yields vastly improved results.

About this manual

This manual focuses on the loudspeakers themselves. In order to fully understand the system, we recommend you also review the manual for the SC-1 System Controller, without which these speakers will not perform correctly.

While we expect your local Wisdom Audio dealer to take care of the setup and calibration of the system, we still recommend that you at least briefly review this and the other manuals (SC-1, SA-series amplifiers) to understand the system’s full capabilities.

Your Sage L150i loudspeakers are specifically designed to avoid the compromises inherent in conventional speaker designs. The active crossover and room correction circuitry in the SC-1 is essential to the speakers’ proper operation. In addition, the SA-series amplifiers are specifically designed to meet the needs of the unique bass system of your Sage L150i speakers. It is truly a “system” design, and not merely a collection of loudspeaker drivers in a box.

Please register your system

To register your warranty, please complete the form at the following address on the internet:

<http://www.wisdomaudio.com/registration/>

Doing so will ensure that there will be no delays should you ever require warranty service. If accessing the internet is inconvenient, you can send a copy of the sales receipt (showing your name, address and the products purchased) to the address shown in the North American Warranty section of this manual.

Wisdom Audio does not and will not ever share its mailing list with other companies. Nor do we expect to contact you frequently, since you are buying a product that should last a lifetime. However, we would like to be in a position to contact you should a software update become available for the system controller (as an example).

Lastly, please keep your sales receipt in a safe and easily found place. If you do not register your purchase with the company, it is your only proof of warranty.

Description

Your Sage L150i loudspeakers take advantage of several critical technologies to deliver a level of performance that has never been available in a loudspeaker that intruded so modestly on your living space. In fact, this level of performance has rarely been attained, regardless of the space and budget at one's disposal.

Since most of these technologies cannot readily be found elsewhere, we will take the time to describe them in more detail than would be necessary for more conventional designs.

Planar magnetic panels

Our planar magnetic drivers use an advanced, thin film membrane to move the air. This film can respond instantly to the smallest detail in the signal. It has vastly less inertia than traditional "cone & dome" drivers, so the signal is never blurred in any way.

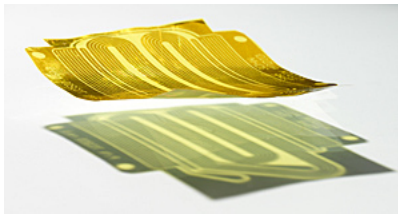

The motive force is provided by a "voice coil" that is printed on the film, which is suspended in a strong magnetic field provided by neodymium magnets behind and in front of the film. The ratio of available force to the moving diaphragm does exactly what it is told; nothing more, nothing less.

Free from compression

One of the most remarkable things about the sound of well-designed planar magnetic speakers is their lack of thermal or dynamic compression. There are several reasons for this:

- The lightweight diaphragm responds quickly to even the smallest signals, yet is robust enough to handle enormous ones.
- The fact that heat does not build up in the voice coil (as it does in conventional dynamic drivers) means that the load seen by the amplifier does not change at high power levels.

When you become accustomed to the sound of your new Sage L150i speakers, conventional speakers sound a bit bland and lifeless.

More reliable

The "voice coil" in the planar magnetic driver is spread out over a large, flat area that is exposed to the open air. As such, when a huge transient comes along, any heat that is generated is immediately dissipated. This compares quite favorably to other designs in which the voice coil is buried inside a massive piece of metal, where the heat has effectively no place to go.



The excellent heat dissipation of these drivers makes them remarkably reliable. Planar magnetic speakers can handle a great deal of power without undue stress or audible strain. In fact, for a given size, they can handle *many times* the power of a traditional dynamic driver.

Easy on amplifiers

Because the conductor is essentially a long, thin wire, it presents a purely resistive load to the amplifier. This is comparable to the simple test loads that amplifier companies use when measuring their amplifiers to show how terrific they are. As such, you can be assured that your amplifiers will sound and work their best.

Line source behavior

Almost all loudspeakers radiate sound into the room as imperfect “point sources.” This means that most of the energy they put into the room expands as an ever-enlarging sphere, as though emerging from a single point in space. This results in a multitude of reflections from the ceiling and floor that can degrade sound quality.

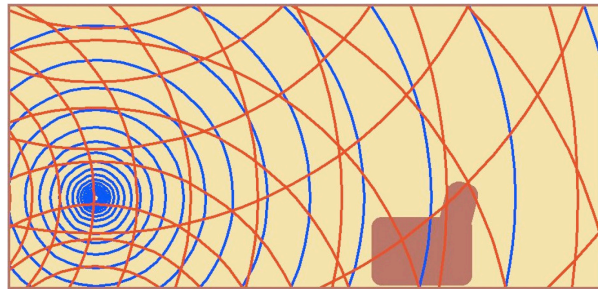

By contrast, the Sage L150i speakers radiate sound as a “line source.” The sound moves into the room as an expanding cylinder, rather than as an expanding sphere — as though from a vertical line suspended in space.

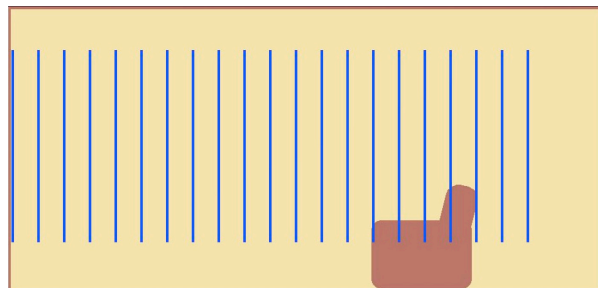

Line source speakers provide two significant advantages:

- ceiling and floor reflections are minimized, resulting in greatly reduced interference, letting you hear more of the speaker and less of the room;
- the sound pressure level (SPL) throughout the room is much more evenly distributed, making it much easier to set the “right” volume, no matter where the audience is seated.

To achieve this highly desirable line source behavior, it is essential to have a tall and slim driver. (Simply stacking multiple “cone & dome” high frequency drivers does not create a proper line source. Instead, it creates a *series* of point sources which end up interfering with each other.) With Wisdom Audio’s planar magnetic technology, it becomes possible to have drivers that are *extremely* tall and slim. In the Sage L150, for example, the active area of the midrange/treble driver is approximately 1” (25mm) wide by 72” (1.8m) tall.

Because of this shape, the sound (even at high frequencies) is distributed uniformly across the width of the room from a driver that “looks” only about an inch wide acoustically. However, the sound is launched in a much more directional way vertically. By minimizing early reflections from the ceiling and the floor, the clarity of the system is greatly enhanced. This is heard in both tremendous musical detail and in much-improved dialog intelligibility.

For more detailed information on the loudspeaker drivers in general, and planar magnetic drivers in particular, please refer to the *Planar Magnetic Technology* white paper that can be found on the Wisdom Audio web site, at www.wisdomaudio.com.

Dynamic woofers

Authoritative, deep bass requires that you move a lot of air. We have chosen to use dynamic woofers for the bass because they still provide the best performance at low frequencies as compared to any alternative technology.

In order to get comparable performance from a planar magnetic design, you would need to have a huge speaker that would be impractical in most domestic living spaces. It simply makes more sense to use the best transducer technology in each area of the reproduced spectrum. One of Wisdom Audio’s strengths is in seamlessly blending these technologies — particularly important given the high standards set by our planar magnetic drivers.

Big bass in small boxes?

There is an old truism in loudspeaker design that goes something like this: “*deep bass, small enclosure, or high sensitivity — pick two out of the three.*” No one can cheat the laws of physics. If you want deep bass from a small box, you will need to make up for the small size with equalization and extra power.

Fortunately, our system design comes to the rescue.

The system design includes both the SC-1 System Controller (which serves as an active crossover, a system-specific equalizer, and a room correction system) and the matching SA-series amplifiers. By dedicating high power amplifiers we can give people what they want: great bass without huge, ugly boxes that are difficult to place.

Extraordinary drivers

Of course, the woofers themselves must be rather extraordinary in order to both handle the power we deliver to them, and to “keep up” with the planar magnetic drivers right up to the crossover frequency.

Our woofers are different because they must be in order to do their job. Specifically, we need highly dynamic, uncompressed bass (to keep up with the planar magnetic drivers) from an unusually small enclosure (so it will fit in the wall). These two design goals require rather extraordinary attention to myriad details.

The magnetic structures employed in the Sage Series woofers are significantly stronger than is commonly available — more than twice as powerful as typical woofers, in fact. In addition, our voice coils are larger and capable of handling more power than would be expected for a driver of similar size. Even the surrounds that attach the diaphragm to the woofer's basket (the metal frame) have to be unusually rugged. Everything about the woofers has been optimized for their intended application, which involves reproducing powerful, dynamic bass from an extremely small enclosure.

Designed for biamplification

People who have wanted to extract the highest performance from their systems have known for a long time that driving each section of the speaker directly and separately yields the finest results. Of course, this requires having a dedicated, active crossover to divide the frequency range appropriately before the power amplifiers, so that they can then drive the speakers directly. It also requires two sets of speaker wires for each loudspeaker.

Biamplification makes use of two channels of amplification to drive different portions of the audio spectrum. The most common instance of "bi-amping" today is in home theater applications, wherein a dedicated subwoofer handles the deepest bass, while the remaining audible range is handled by the various front and surround speakers. But you can also biampify a full range loudspeaker, driving the woofer separately from the drivers that handle the midrange and treble frequencies. Your Sage L150i is such a speaker, designed to use separate amplifiers for the woofer and the planar sections of each loudspeaker.

Since each channel of the amplifier is delivering current into its load only over a limited range of frequencies, several forms of distortion are reduced as compared to each channel handling the full range of musical information. Moreover, since each amplifier is "direct-connected" to the driver for which it is responsible, there are no passive component losses and the amplifier can control the motion of its assigned transducer with far greater finesse and precision.

But perhaps most importantly, biampification allows us to dedicate the amount of high quality power required to deliver outsized bass from small enclosures. It would not be practical or even possible to obtain bass performance on this level without a dedicated amplifier driving the woofers solely and directly.

SC-1 System Controller

In order to realize these benefits, an active crossover must accurately divide the signal into the low and high ranges. The Wisdom SC-1 System Controller serves that purpose, while also providing both system-specific equalization (to compensate for the unusually small woofer enclosures) and sophisticated room correction to minimize distortions introduced by the room itself. The goal is simple: to achieve consistently excellent results in the real world of the owner's home.

After all, that's all that really matters.

Unpacking & Installing the L150i

Your new Wisdom Audio Sage L150i in-wall speaker is a substantial piece of equipment. Please exercise caution when unpacking your L150i to ensure that you do not strain yourself from its (perhaps unexpected) weight.



Caution!

Do not attempt to lift your L150i by yourself. Unpacking these speakers is easy for two people, but it is unwise for a single person to attempt doing so.

Do not attempt to lift your L150i while bending or twisting from the waist. Use your legs for lifting, not your back.

Always stand as straight as possible and keep the L150i close to your body to reduce strain on your back.

The loudspeaker comes “telescoping” boxes (two five-sided boxes, one of which fits snugly inside the other). Gently roll the box over so that its bottom is facing up. Then carefully cut the tape along the bottom of the box on all four sides. Roll the box over again so the bottom is on the floor, and lift off the top. With one person at each end, carefully lift the speaker components out of the box and lay them on a soft surface (carpet or similar).

There are three major pieces involved in a single L150i loudspeaker:

- the Uni-Grip™ in-wall mounting systems (two included)
- the high operating pressure bass module
- the planar magnetic midrange/treble module

Note that the two Uni-Grip™ frames for the L150i are not interchangeable, due to differences in the pattern of threaded holes used to attach the planar and woofer speaker modules to the frame of each Uni-Grip™. Pay close attention to the labeling on each, which indicates “Planar Section, Top” or “Woofer Section, Top” respectively.

In most cases, the planar magnetic section of the L150i will be inside of the woofer sections. In addition, the two sections must be within approximately 5” of each other and should typically flank either side of a stud.

Because of the magnitude of the bass energy of which the L150i is capable, it is strongly recommended that the walls into which the L150i is installed are reinforced and as strong as feasible.

In new construction or remodeling applications, we recommend framing in dedicated spaces that are between 10-11 inches wide for the woofer sections, just slightly wider than the 9.52 inches required by the Uni-Grip™ frame. If the wall is going to be skim-coated with plaster after construction, consider using 3/4-inch plywood or MDF for the wall for superior strength. (This approach is advantageous for the woofer sections; the reaction mass of the planar section is extremely low, and does not require this level of reinforcement.)

1. Determine the area for the speaker installation and locate the cutout guide using push pins to secure it in place. Ensure that the template is plumb using a bubble level or similar. Note: Make cer-

tain that there are no studs, plumbing or electrical conduit in the intended area behind the wall before you begin marking and cutting!

2. Trace the outer perimeter of the cutout guide with a pencil or a utility knife.
3. Remove the traced section of the wall using a keyhole saw, and clear debris from the edge of the hole.
4. Push any insulation to the side.
5. Disassemble bezel/Uni-Grip™ and place the supplied Allen head screws to the side. Place the bezel in the wall cutout and insert the Uni-Grip clamping bar through the opening at an angle, working on one side first. Reinstall the Allen head screws with the supplied 3/32" drill bit, securing both pieces to each other (sandwiching the wall between them), but do not tighten yet. Repeat on the other side.
6. Using a level, adjust assembly in wall cutout to ensure that the assembly is plumb. Tighten the Allen screws. Do not over torque or strip these screws. The large clamping area of the Uni-Grip system does not require unusually high torque on the screws to be secure.
7. Paint the bezel and grill as necessary, being careful not to plug up the holes in the grille. Note that the speaker modules are not mounted in the bezel and grille assembly at this time. They can be mounted later, after all the paint is dry.
8. Using assistance to hold the speaker modules away from the wall, connect all three speaker wires (planar magnetic section, plus two woofer section speaker cables) to the connectors at the ends of the back boxes, paying attention to assign the correct band-pass and polarity to their respective speaker connectors.

Important Note:

The Wisdom Audio L150i is a biamplified speaker that requires *three* sets of speaker wire to each location rather than the usual two. One pair of connections is for the planar magnetic module, whereas the woofer module uses two sets of connections, one each for six of the twelve woofers. The Wisdom Audio SA-1 system amplifier is designed to provide two identical outputs for the woofer sections of a given speaker, for a total of 1000 watts of power for the bass.

All connections are made at the bottom end of the enclosures.

9. Insert the speaker/back box assembly into the Uni-Grip frame and attach using the supplied Allen head screws and 3/32" drill bit. Do not over torque or strip these screws.

Room Acoustics & Placement

Wisdom Audio believes in equalization. Assume for a moment that you had a “perfect” loudspeaker: as soon as you place it in your room, its perfection is gone. In fact, even *good* rooms often introduce deviations of 20 dB to the response of the system, particularly at low frequencies.

It seems strange to us to worry about tenths-of-a-decibel differences between one component and another when there are 10-20 dB problems right there in the room with you.

At the same time, room equalization is not a panacea. It does not solve all problems. In fact, and somewhat paradoxically, EQ works best when it has the least to do. It is best used as the “finishing touch” on an otherwise good system. Unfortunately, most people do not understand that the most important component in their system is their listening room.

This manual does not have the space for a full description of everything that goes into creating excellent room acoustics; doing so would require a textbook of several hundred pages. Instead, we will give you some ideas, and some references to pursue should you want to learn more.

Start With the Room

There are many myths floating around pertaining to what a “good room” should be like. One of the most common is that it should have non-parallel walls. Without going into the details, we recommend staying with rectangular rooms whose dimensions do *not* share common divisors.

Thus a room with dimensions of 8’ by 16’ by 20’ would be quite poor (since the dimensions are all divisible by a length of 4’, and 16 is also multiple of 8). This commonality of dimensions results in large standing wave problems at low frequencies. By contrast, a room whose dimensions are 9’ by 16’ by 29’ would be much better, since none of the dimensions are mathematically related to one another.

There are infinite variations on this idea. If you have the flexibility to choose (or modify) your room dimensions to avoid such problems, do so. Either way, our room correction will be a big help.

Rigid Walls

Another myth that should be dispelled is the notion that the walls (and ceiling and floor) of the room should be extremely rigid in order to reproduce good bass. Rigid, inflexible walls reflect energy extremely well; thus you will keep more of the bass energy in the room. This much is true. However, those rigid walls will only increase the amplitude of the standing waves that your room naturally supports. In simple terms, you will have *more* bass, but it will also be *more irregular*, with larger peaks and valleys in the response.

Walls that flex a bit (but do not rattle) are much better. Coincidentally, traditional American residential construction standards (sheet rock on wooden studs) are not a bad place to start. You can do better still with professional help, but studs and sheet rock are better than poured concrete. (If your listening room is in the basement, a false wall can easily be built in front of the concrete. You probably need something like this for insulation and aesthetics anyway.)

The ultimate in dedicated listening room construction involves the design and construction of floating walls, ceiling and floor. This approach yields the added benefit (when done properly) of providing outstanding acoustic isolation from adjacent spaces as well as superb bass reproduction. This approach goes well beyond the scope of an owner's manual; if you are interested, you should contact a professional acoustician who has specialized in this sort of domestic room design.

Speaker Placement

Within the room itself, placement of the speakers and the listener will have a profound effect on the performance of the system, particularly below 300 Hz or so. There is no "perfect" position that will solve all problems, but finding the best compromise will make it easier to solve the remaining problems with the SC-1.

Your Wisdom Audio dealer can help you with optimizing your speaker placement, which is never quite as simple as it seems it should be. The characteristics you should listen for are several:

Left & Right Speakers

Goal #1: Stable, 3-dimensional stereo imaging

This usually requires reasonable symmetry within the room, and a bit of space between the speakers and adjacent side walls (to minimize the adverse effects of early first reflections). Mono (correlated) pink noise can help here, though it does not replace listening to music. With pink noise playing in both speakers, you should hear a tightly-defined little "ball" of pink noise floating in space exactly halfway between the speakers.

Goal #2: Smooth, consistent bass

Oft-cited rules of thumb for smoother bass reproduction include both "placing the speakers at different distances from the side walls vs. the wall behind them," and "placing them at 'odd fractions' of the room's dimensions" (e.g., fractions in which the denominator is an odd number, like $\frac{1}{3}$, $\frac{2}{5}$, $\frac{2}{7}$, etc.). But nothing replaces your experience in your room, combined with your dealer's experience in a variety of rooms. Playing pink noise through the woofer sections of your Wisdom Audio speakers (with the microphone at the listening position, and prior to doing any equalization) and watching the results on a Real Time Analyzer (RTA) will let you see the results of your labors.

Center Channel

Center channel height

Once you have a solid stereo image up front (when listening only to the Left and the Right speakers), you need a center channel speaker for multichannel reproduction. It should be centered between the Left and Right, and centered on the screen's location, preferably at the same height as the Left and Right speakers. This presents an obvious problem: you cannot place a speaker in front of your television screen.

Ideally, a center channel speaker would be behind an acoustically transparent front projection screen and would match the Left and Right speakers. Doing so would ensure the best possible consistency of tonal balance, image height, and dynamic capabilities for the critical center channel.

Another way to achieve similar results without relying on an acoustically transparent front projection screen is to use a total of four front speakers:

- two widely-spaced L150i speakers handle the Left and Right channels;
- two L150i speakers closely flanking the screen both play the (mono) center channel signal.

This approach creates a stunningly convincing “phantom” center image that appears to emerge directly from the center of the picture, while allowing you to use any display device you choose.

Failing an acoustically transparent screen or a phantom center channel approach, the important thing is to match the tonal and dynamic capabilities of the Left and Right speakers while minimizing the change in image height as a sound is panned across the front stage. Wisdom Audio has designed horizontally-oriented planar magnetic hybrid speakers that will match your L150i loudspeaker superbly; place them as close to the edge of the screen as is practical.

Surround Speakers

Surround channel geometry

In a 5.x channel system, the surround should be placed either directly to the sides of or slightly behind the listening area (90° – 110° from the center channel, as seen from above). In a 7.x system, the surround speakers should be closer to 90° from the center speaker, and the surround back speakers should be at approximately 135° – 150° from the center speaker. This conforms to industry standards, and ensures that you hear what was intended from a spatial placement point of view. (Too often, the surround speakers are all behind the listeners, creating a big “hole” in the soundfield between the front and the back.)

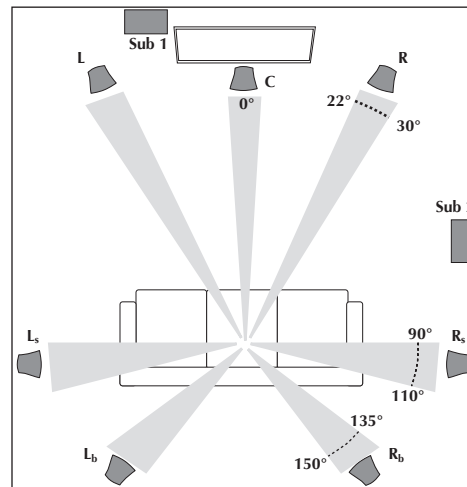

a 7.2 channel system layout

One possible exception to these guidelines: if you have a THX®-certified processor and are using the THX Advanced Speaker Array™ circuitry, you should follow the guidelines in your owner’s manual for the processor. Using this technology, it can actually be more effective to have the rear speakers in a 7.x system directly behind you and immediately adjacent to each other.

Subwoofer Placement

Subwoofers offer somewhat greater flexibility in placement, since the frequencies they reproduce are not readily localizable by the human ear. This is due to the fact that the wavelengths they reproduce are more than ten feet (3 meters) long, but our ears are located only about 6-7 inches (17 cm) apart. Thus these

extremely long waves do not contribute meaningfully to the imaging that the main speakers create.

However, this fact does not mean that the placement of the subwoofers has no effect on the sound quality in the room. Far from it. The subwoofers are the *most* likely to suffer from the response irregularities introduced by the room itself, operating as they do below approximately 80 Hz in most systems.

Recent research into the behavior of rooms as a function of speaker placement has concluded that — if you have the freedom to do so — there are significant advantages to placing several smaller subwoofers around the room, rather than relying on a single large woofer. Moreover, the optimum placement is usually centered on each of the four walls. If you have the luxury of doing so, this simple placement strategy can reduce the size of the room’s response irregularities from 20 decibels down to perhaps as little as 6-8 decibels—a tremendous improvement.

Reducing the room’s inherent problems to this degree provides a huge advantage. It allows the SC-1 System Controller to put its considerable abilities to work on *perfecting* your system’s response, rather than on trying to perform major corrective surgery.

Room Treatment

Rectangular rooms have six reflecting surfaces (four walls, ceiling and floor) that reflect sound to the listener, after various delays introduced by the indirect routes the sound take on their way to the listener. These first reflections are particularly damaging to sound quality. Looking at the simplest case of stereo reproduction, you have a minimum of *twelve* first reflection points in your room that deserve some attention.

Unfortunately, it is often difficult to do much about the ceiling and floor reflections, even though they are arguably the most destructive. (The minimization of these reflections is one of the strongest arguments for the tall, line source loudspeakers that Wisdom Audio builds.) This leaves you with eight “first reflections” that you should consider minimizing somehow. These points are easily found by having an assistant slide a small mirror along the four walls of the room, while you sit at the listening position. Any place on the wall where you can see a reflection of *any* speaker is a first reflection point. Concentrate on the first reflections for the Left and Right speakers first.

If you can, arrange to apply either absorption or diffusion at these eight points (don’t forget the wall behind you). Absorption can be as simple as heavy, insulated drapes; diffusion can be provided by a well-stocked bookcase with books of varied sizes. Alternatively, you can buy purpose-designed room treatments (some sources listed under References, below).

The important things to remember are these: a good room should have a balance of absorption and diffusion; and if you are going to treat only a few areas of the room, the first reflection points are the most important ones to treat.

Professional Acoustic Design

Does this all sound too complicated? For good reason. It *is* complicated.

The difference between the average listening room and one that is professionally designed and implemented is huge. A great listening room will disappear to an astonishing degree, letting the experiences captured in your recordings speak to

you directly. A well-designed room is also quieter and more comfortable. It can easily become a favorite retreat for peace and rejuvenation.

If you decide to investigate the possibility of improving your room with the help of a professional, it is important to find someone who focuses on residential spaces. Most acousticians are trained to deal with large spaces — airports, auditoriums, lobbies in commercial buildings, etc. The problems seen in “small” rooms (residential spaces) are quite different, and outside the experience of most acousticians. Find someone who specializes in and has a great deal of experience designing home studios, home theaters, and the like. Your Wisdom Audio dealer may be such a person; failing that, he/she can help you find such a professional.

References

Books on Acoustics:

The Master Handbook of Acoustics, F. Alton Everest, TAB Books

Sound Reproduction: The Acoustics and Psychoacoustics of Loudspeakers and Rooms by Dr. Floyd Toole, Focal Press

Suppliers of Acoustic Treatments:

Acoustic Innovations, <http://www.acousticinnovations.com/>

Acoustic Sciences Corporation, <http://www.acousticssciences.com/>

Echo Busters, <http://www.echobusters.com>

MSR Acoustics, http://www.msr-inc.com/home_theater/hometheater.html

RPG Diffusor Systems, <http://www.rpginc.com/>

Optimizing the System

A Wisdom Audio loudspeaker system is just that: a *system*, designed to provide the highest calibre of performance, in the widest variety of possible settings. As such, simply connecting all the wires does not mean the system is optimized.

The SC-1 System Controller manual has the pertinent details on precisely how to use it to optimize the performance of the system. For the purposes of this manual, a quick overview of the process is sufficient.

1. **Tell the SC-1 which speakers are in the system**

The software application that configures the SC-1 for your specific system has a series of menus that allow your installer to designate which model of Sage loudspeaker is used in each channel of the system. This allows you to mix and match freely, based on the best speaker for a given location.

2. **Measure the room**

Your installer will use a calibrated reference microphone to accurately measure the performance of each speaker at multiple locations in the listening area. This process ensures that the entire listening area is optimized, rather than optimizing only one location at the expense of others.

3. **Select an appropriate target**

Large and small rooms have intrinsically different traits. The room correction software allows for these characteristics to be taken into account for superior results.

4. **Calculate the necessary room correction**

The software then uses the power of the PC to calculate the correction filters your room requires, and downloads them into the SC-1 for you to audition.

5. **Listen and save the result**

You can listen to each set of correction filters prior to deciding whether it meets your expectations. Once you are satisfied, you can permanently save the results to the SC-1 (eliminating the need for the PC).

This process can be repeated if necessary, and a total of up to three independent setup memories can be saved for different needs. For example, you might want different setup memories for different conditions such as drapes open vs. closed, or perhaps different target curves for different content (music, movies, gaming). Each of these setup memories can be saved to the SC-1 and then selected as needed, with from the SC-1's front panel, or via RS-232 and a control system your installer would create for you.

Care & Maintenance

To remove dust from the cabinet of your L150, use a feather duster or a lint-free soft cloth. To remove stubborn dirt and fingerprints, we recommend isopropyl alcohol and a soft cloth. Lightly dampen the cloth with alcohol first and then clean the surface of the L150i with the cloth. Do not use excessive amounts of alcohol—there is no need for the cloth to be wet; merely damp is better.

In the case of stubborn or grimy substances that do not come off the textured surfaces easily, use a clean, plain, pink eraser (such as you might give your child for school work) to remove the dirt. Then finish with a soft cloth lightly dampened with alcohol as outlined above.

Never attempt to clean the drivers themselves.



Caution!

Do not touch the surface of the planar magnetic drivers, under any circumstances. The thin film has been carefully pre-tensioned at the factory; any subsequent contact can only damage it.

North American Warranty

Twenty Year Warranty

When purchased from and installed by an authorized Wisdom Audio dealer, Wisdom Audio® loudspeakers are warranted to be free from defects in material and workmanship under normal use for a period of twenty years from the original date of purchase.

During the warranty period, any Wisdom Audio loudspeaker exhibiting defects in materials and/or workmanship will be repaired or replaced, at our option, without charge for either parts or labor, at our factory. The warranty will not apply to any Wisdom Audio loudspeaker that has been misused, abused, altered, or installed and calibrated by anyone other than an authorized Wisdom Audio dealer.

Any Wisdom Audio loudspeaker not performing satisfactorily may be returned to the factory for evaluation. Return authorization must first be obtained by either calling or writing the factory prior to shipping the component. The factory will pay for return shipping charges only in the event that the loudspeaker is found to be defective as mentioned above. There are other stipulations that may apply to shipping charges.

There is no other express warranty on this loudspeaker. Neither this warranty nor any other warranty, express or implied, including any implied warranties of merchantability or fitness, shall extend beyond the warranty period. No responsibility is assumed for any incidental or consequential damages. Some states do not allow limitations on how long an implied warranty lasts and other states do not allow the exclusion or limitation of incidental or consequential damages, so the above limitation or exclusion may not apply to you.

This warranty gives you specific legal rights, and you may also have other rights which vary from state to state. This warranty is applicable in North America only. Outside of North America, please contact your local, authorized Wisdom Audio distributor for warranty and service information.

To register your warranty, please complete the form at the following address on the internet:

<http://www.wisdomaudio.com/registration/>

Doing so will ensure that there will be no delays should you ever require warranty service.

If accessing the internet is inconvenient, you can send a copy of the sales receipt (showing your name, address and the products purchased) to:

Wisdom Audio
1572 College Parkway, Suite 164
Carson City, NV 89706

For more information:
www.wisdomaudio.com
information@wisdomaudio.com
Ph: 775.887.8850
Fax: 775.887.8820

Obtaining Service

We take great pride in our dealers. Experience, dedication, and integrity make these professionals ideally suited to assist with our customers' service needs.

If your Wisdom Audio loudspeaker must be serviced, please contact your dealer. Your dealer will then decide whether the problem can be remedied locally, or whether to contact Wisdom Audio for further service information or parts, or to obtain a Return Authorization. The Wisdom Audio Service Department works closely with your dealer to solve your service needs expediently.



Important!

Return authorization must be obtained from Wisdom Audio's Service Department BEFORE a unit is shipped for service.

It is extremely important that information about a problem be explicit and complete. A specific, comprehensive description of the problem helps your dealer and the Wisdom Audio Service Department locate and repair the difficulty as quickly as possible.

A copy of the original bill of sale will serve to verify warranty status. Please include it with the unit when it is brought in for warranty service.



Warning!

All returned units must be packaged in their original packaging, and the proper return authorization numbers must be marked on the outer carton for identification. Shipping the unit in improper packaging may void the warranty, as Wisdom Audio cannot be responsible for the resulting shipping damage.

Your dealer can order a new set of shipping materials for you if you need to ship your loudspeaker and no longer have the original materials. There will be a charge for this service. We strongly recommend saving all packing materials in case you need to ship your unit some day.

If the packaging to protect the unit is, in our opinion or that of our dealer, inadequate to protect the unit, we reserve the right to repackage it for return shipment at the owner's expense. Neither Wisdom Audio nor your dealer can be responsible for shipping damage due to improper (that is, non-original) packaging.

Specifications

All specifications are subject to change at any time, in order to improve the product.

- **Frequency response:** 20Hz – 20 kHz \pm 2dB relative to the target curve
- **Impedance, planar section:** 4.5 ohms resistive
- **Impedance, woofer section:** 8 ohms nominal, 6.5 ohms minimum
- **Sensitivity, planar section:** 96 dB/1w/1m
- **Power handling, peak:** >1000w
- **Dimensions** see appropriate Dimensions drawings
- **Shipping weight, bass section:** 90 lbs. (41 kg)
- **Shipping weight, planar section:** 53 lbs. (24 kg)

For more information, see your Wisdom Audio dealer, or contact:

Wisdom Audio
1572 College Parkway, Suite 164
Carson City, NV 89706
www.wisdomaudio.com
information@wisdomaudio.com
Ph: 775.887.8850
Fax: 775.887.8820

L150i Bass Section Dimensions

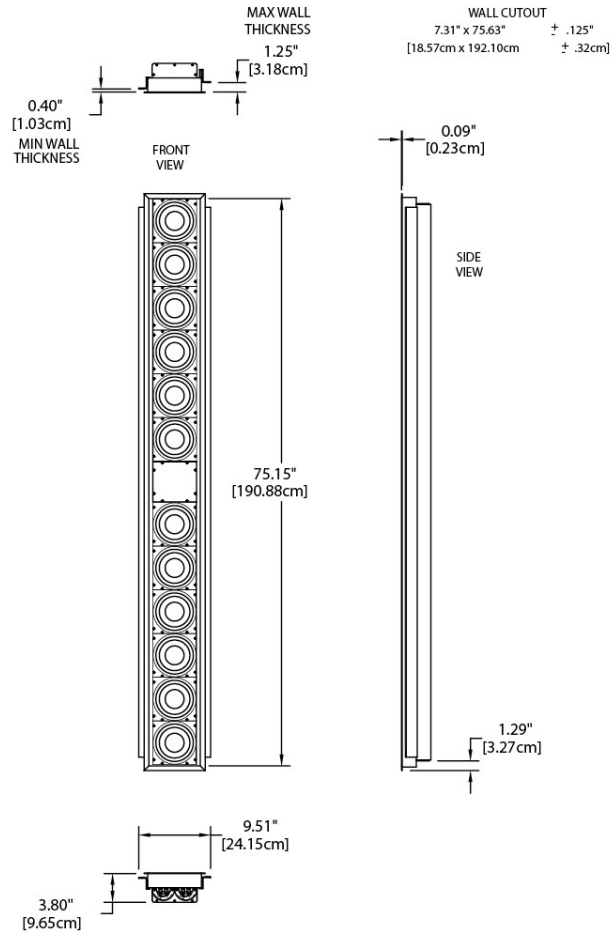

L150i Planar Section Dimensions

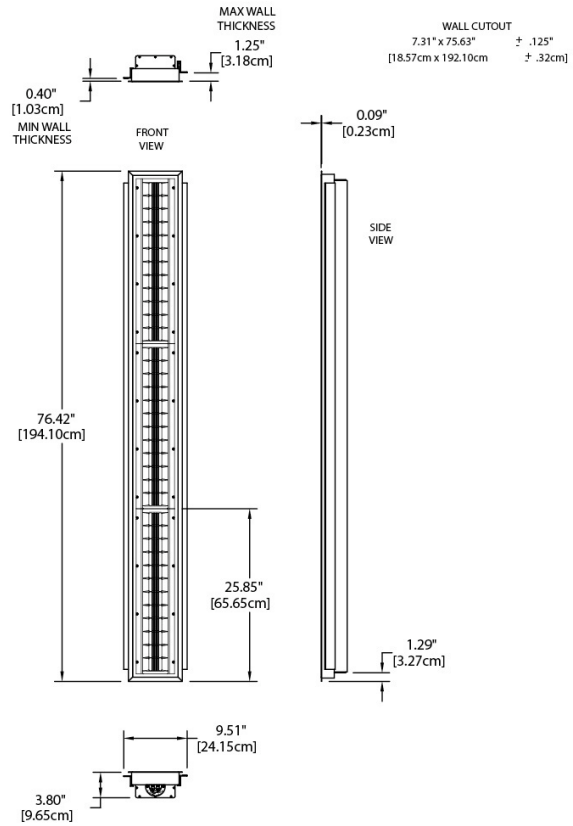



W I S D O M[®]

WISDOM and the stylized W are registered trademarks of Wisdom Audio.

Wisdom Audio
1572 College Parkway, Suite 164
Carson City, Nevada 89706 USA

Telephone: 775.887.8850
Fax: 775.887.8820